

**HONDA POWERED**

# Aussie Fire Chief

*OUT PERFORMS AND OUT FEATURES ALL OTHERS*

Genuine Honda  
GX series 5.5HP

- Metal caps & chains
- Separate replaceable suction flange
- BIG 2" suction port
- Big belly body means FAST priming
- BIG drain plug
- Steel skids with anti-vibration mounts

Ad price  
**\$880** inc  
gst

POWERED by  
**HONDA**

**GX** Engine **3** YEAR WARRANTY

Also available

Diesel drive options



*Aussie Pumps*  
**5year**  
pump warranty

**Performance...** QP205SE/GX160

Max flow 450 lpm  
Max head 75m  
5.5HP Honda GX series  
Self primes FAST from 7.6m

The biggest impeller  
in the business - 2.5 times  
heavier than competitors ...  
more water & more pressure

Huge 7½" diameter

Distributed by

**AUSTRALIAN PUMP**

RELIABLE PRODUCTS ... RELIABLE PEOPLE

[www.aussiepumps.com.au](http://www.aussiepumps.com.au)

Model Numbers: **Aussie Fire Chief**  
**Aussie Fire Captain**  
**Aussie Fire Captain Plus**

**Aussie "Mr T"**  
**Aussie QP305**

**FIVE YEAR PUMP END WARRANTY ON ALL AUSSIE QUIK PRIME PUMPS**

The Aussie Fire Chief, the Fire Captain and "Mr T" super high pressure twin impeller fire pumps are regarded as the world's finest lightweight portable high pressure pumps. The Fire Chief has won significant contracts both within Australia and in export markets.

Extraordinary performance, quality components and ease of serviceability makes the Aussie Fire Chief is the choice of farmers and professional fire fighting authorities around the world.

### **Aussie Fire Chief (QP205SE)**

Designed to out-perform and out-feature all other portable fire fighting pumps, the Aussie Fire Chief offers users significant quality features.

These include a huge 7½" diameter, one piece impeller that weighs 2½ times more than impellers in other brands. The big belly body provides large water passages allowing more water to get through the pump and significantly aiding performance.

The pump will produce flows of up to 450 litres per minute and heads as high as 75 metres. The basic engine is a genuine built Honda 5.5HP four stroke engine with oil alert, low oil protection, cast iron cylinder bore in conformance with tough international environmental emission standards. The Fire Chief comes with anti vibration mounts, steel skids and handle as standard equipment.

### **Aussie Fire Captain (QP205S)**

The Captain comes in the same configuration as the Aussie Fire Chief but with heavy duty steel roll frame instead of steel skids. Supplied with anti vibration mounts, the frame provides extra protection for the unit and added ease of transport.

### **Aussie Fire Captain Plus (QP205SL)**

A big single impeller Aussie Fire Chief pump but with a 6.5HP, 9HP or 13HP Honda four stroke petrol engine all supplied with oil alert and cast iron cylinder bore. Electric start option available on all models.

Standard equipment includes full heavy duty roll frame with pump performance figures of up to 510 litres per minute flow, 75 metres head.

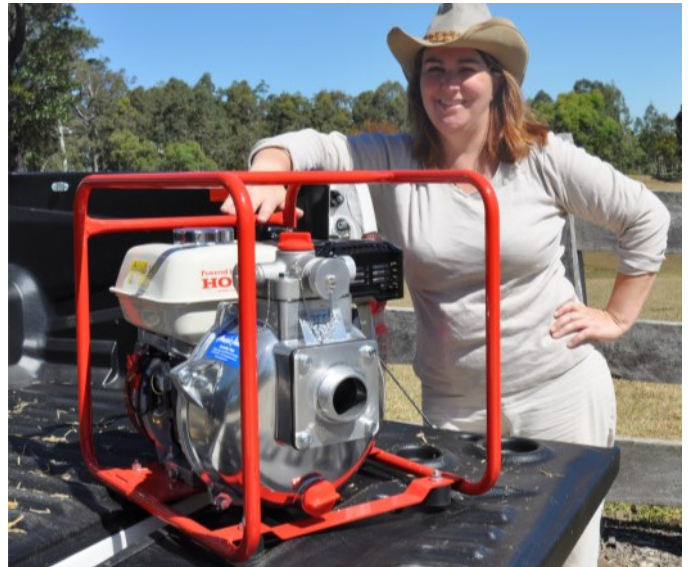

### **Aussie "Mr T" Twin Impeller Fire Pump (QPT-205SLT)**

The Aussie "Mr T" is the final extension of development of the Aussie Fire Chief. It is a heavy duty twin impeller pump but with a difference!

The huge, closed vane dual impellers create a combination of high pressure and high flow that is unmatched, max head is 95 metres, max flow is 480 litres per minute.

The Aussie "Mr T" twin impeller range is available with 9HP or 13HP Honda four stroke engine power as standard equipment with electric start option available. "Mr T" is available with 2" x 2" ports, 2" x 3-way ports (1½", 1", 1") or with 3" x 3".

### **Aussie QP305SL 3" High Pressure Pump**

The 3" version of the Aussie Fire Chief, the QP305SL is available in a wide range of options that provide flows of up to 510 litres per minute and heads as high as 68 metres.

Engine options include 5.5HP, 6.5HP, 9HP and 13HP Honda four stroke engines with oil alert and cast iron cylinder bore.



### **Five Year Warranty:**

Aussie Quik Prime pumps carry a unique pump end five year warranty. The products are guaranteed to be free of faulty workmanship or material for a period of five years after the date of sale to the end user.



Only top quality genuine brand engines by reputable manufacturers are used. A three Honda year engine manufacturer's warranty applies, administered by the engine manufacturer or it's duly appointed representative. All engines used by Australian Pump Industries are major international brands, serviced and supported not only in Australia and South Pacific but right throughout the world.



Quality  
ISO 9001  
SAI GLOBAL





**Fire Chief**

### Applications:

- Fire fighting, mop up and general fire protection
- High pressure water transfer
- Spray irrigation
- Diesel fuel transfer
- High pressure spraying
- Sheep jetting
- Boom spraying
- Stock crate wash down
- Machinery wash down



### Features

- Five year warranty
- Lightweight portable
- Fast self priming from 7.6 metres
- Replaceable flanged suction port cover and discharge elbow
- Available with Honda four stroke petrol engines (three year warranty)
- Skids with rubber feet and carry handle as standard
- Full frame with anti vibration mounts (option for Fire Chief, standard on all other versions)
- Single piece, heavy duty closed impeller
- Three way outlet
- Big 2 inch inlet
- Big belly body
- Three way outlet has top quality metal caps with chains
- Big drain port
- Big integrated priming port
- Optional Viton seal and o-ring kit
- Optional diesel engine drive versions
- Hydraulic drive option

### Benefits

- » Great quality ... use with confidence
- » Weighs from only 23kgs
- » Ready to pump in minimum amount of time
- » Easily replaced if thread damaged, easy to service check valve without dismantling pump
- » Tried and proven with established service networks throughout the world
- » Feet absorb vibration - stable in operation
- » Protects pump, facilitates transport on site
- » Pumps more water at high pressure, saves fuel
- » Enables choice of plumbing sizes from 1" to 1 1/2"
- » Lets more water into the pump
- » Larger water passages mean more water efficiency, lower fuel costs
- » Top quality, ensures outlet cap security
- » Fast, easy pump draining
- » Facilitates fast self priming
- » Enables pump to be used in some herbicide or insecticide spraying applications
- » Fuel economy, engine longevity
- » Eliminates the need for a separate engine ... reduces costs

Model	Engine Make	Type	Engine Model	HP	Max Head (m)	Max Flow (lpm)	Suct port	Discharge ports	Self primes to (m)
Fire Chief (QP205SE)	Honda	4 Stroke Petrol	GX160	5.5	75	450	2"	2x1", 1x1 1/2"	7.6
Fire Captain (QP205S)	Honda	4 Stroke Petrol	GX160	5.5	75	450	2"	2x1", 1x1 1/2"	7.6
Fire Captain Plus (QP205SL)	Honda	4 Stroke Petrol	GX200	6.5, 9	75	510	2"	2x1", 1x1 1/2"	7.6
Mr T Twin impeller (QPT-205SLT)	Honda	4 Stroke Petrol	GX270 or GX390	9, 13	95	480	2"	2x1", 1x1 1/2"	7.6
QP305SL	Honda	4 Stroke Petrol	GX160, GX200, GX270 or GX390	5.5, 6.5, 9, 13	70	450	3"	3"	7.6
3" Mr T Twin impeller	Honda	4 Stroke Petrol	GX270 or GX390	9, 13	95	500	3"	3"	7.6

NOTE: Aussie stock codes for QP pumps are determined by using the pump & engine model, for example QP205SL/GX200E is the 6.5HP Honda, electric start version of the QP205SL

Model Numbers: Aussie Fire Chief  
Aussie Fire Captain  
Aussie Fire Captain Plus

Aussie "Mr T"  
Aussie QP305

**FIVE YEAR PUMP END WARRANTY ON ALL AUSSIE QUIK PRIME PUMPS**

### Construction:

Front case	Marine grade aluminium
Volute	Marine grade aluminium
Back plate	Marine grade aluminium
Mechanical seal	Carbon/ceramic
Outlet	Marine grade aluminium
Casing bolts	Zinc plated steel
Check valve	Nitrile rubber
Priming & drain plugs	Polycarbonate
Casing, priming & drain plug o-rings	Nitrile rubber
Finish	Brushed aluminium
Impeller	Marine grade aluminium, closed type



Fire Captain



Mr T Twin Impeller

### Optional Accessories:

- Heavy duty suction hose
- Fire fighting hose kits including deluxe hose kit with two 20 metre delivery hoses and fire fighting nozzles
- Coupling Kit
- Strainer

### Dimensions:

Fire Chief

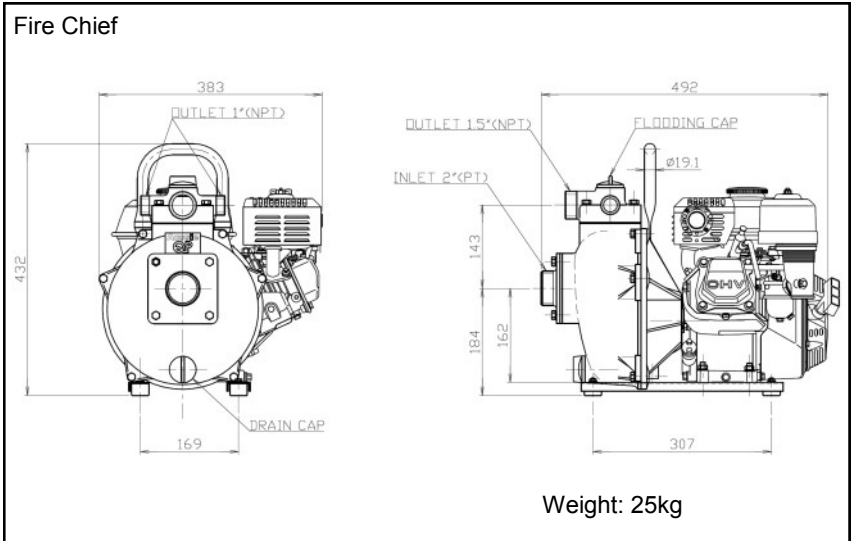

Weight: 25kg

### Models with Roll Frames

	Width (mm)	Height (mm)	Length (mm)	Weight (kg)
Fire Captain (QP205S/GX160)	386	460	523	32
Fire Captain Plus (QP205SL/GX200FF)	386	460	523	35
Mr T Twin Impeller (QP205-TSLT/GX270)	510	610	710	57
Aussie QP305/GX200	386	460	523	35
3" Mr T Twin Impeller	510	610	710	57

### Performance Curve:

